



BONHOEFFER

ENGINE WORKSHOP MANUAL

**BON-P-GE-7.0HP, BON-P-GE-9.0HP, BON-PGE-13.0HP,
BON-P-GE-14.0HP, BON-P-GE-16.0HP**

PREFACE

This workshop manual covers the construction, function and servicing Procedures of the BONHOEFFER MACHINES PVT. LTD

CONTENTS

PERFORMANCE CURVE	1
WIRING DIAGRAMS	2
GENERAL SAFETY	3
SPECIAL TOOLS	4
TROUBLESHOOTING	5
ENGINE OIL	6
OIL ALERT	7
VALVE CLEARANCE	8
SPARK PLUG	9
DIMENSIONS	10

PERFORMANCE CURVES

Tests were conducted according to SAE standard No. J607a. Power curves are for standard sea level atmospheric pressure of 29.92 in. (760 mm) Hg at a temperature of 60° F (15.6°C). Power curves are of a standard test engine equipped with standard air cleaner, muffler and other power consuming devices. Power output will decrease 3.5 % for each 1,000 ft. (305 m) of elevation above sea level and 1% for each 10°F (5.6°C) rise above the standard temperature of 60°F (15.6°C). As shipped, production engines will develop not less than 90% of the "Maximum B.H.P."

After being run-in, they will develop not less than 95% of the "Maximum B.H.P." For practical operations, the B.H.P. load and engine speed should not exceed the limit defined by the "Recommended Maximum Operating B.H.P." curve. Continuous operation should not exceed 85% of the Maximum B.H.P.

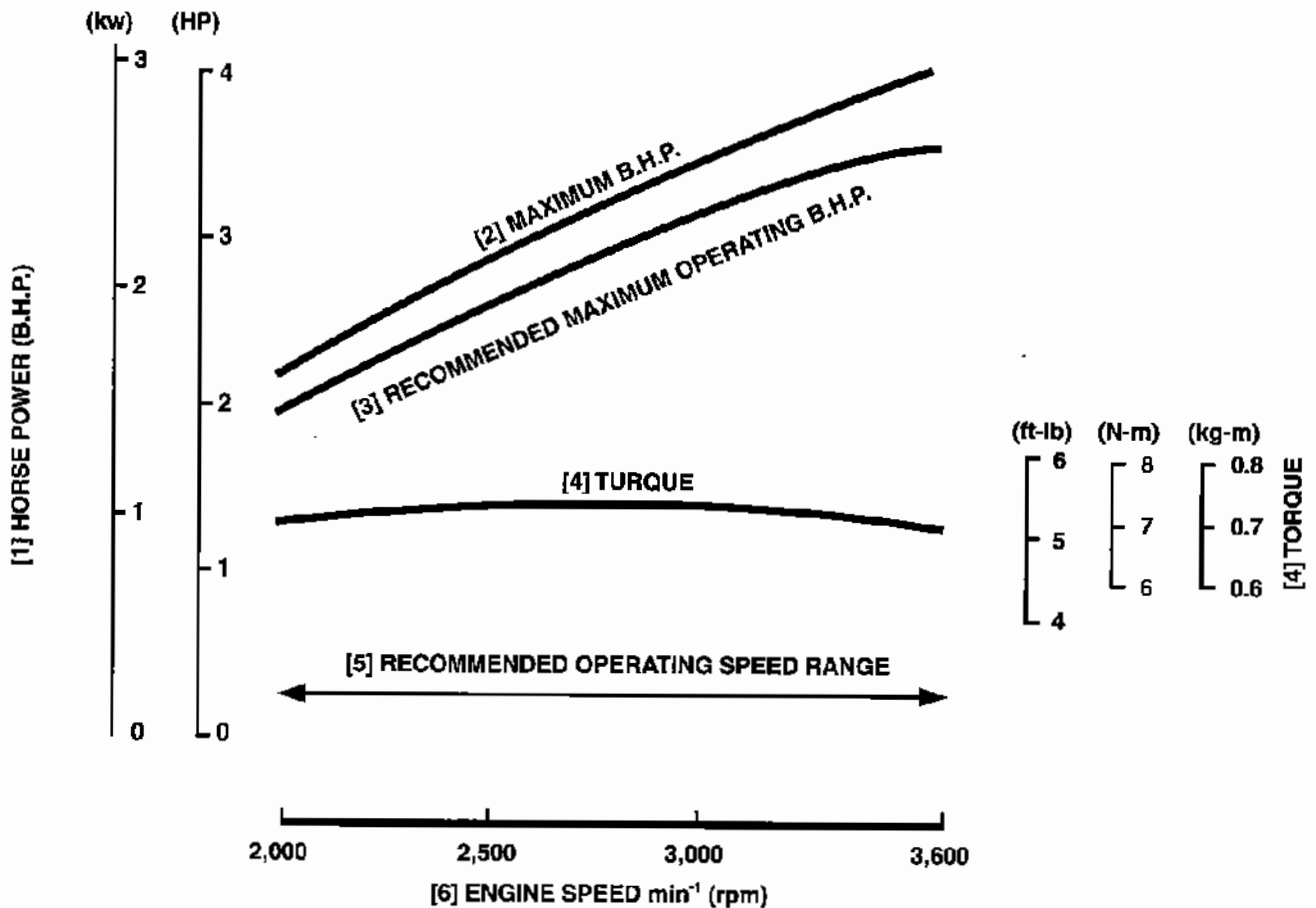

WIRING DIAGRAMS

<Without electric starter and oil alert>

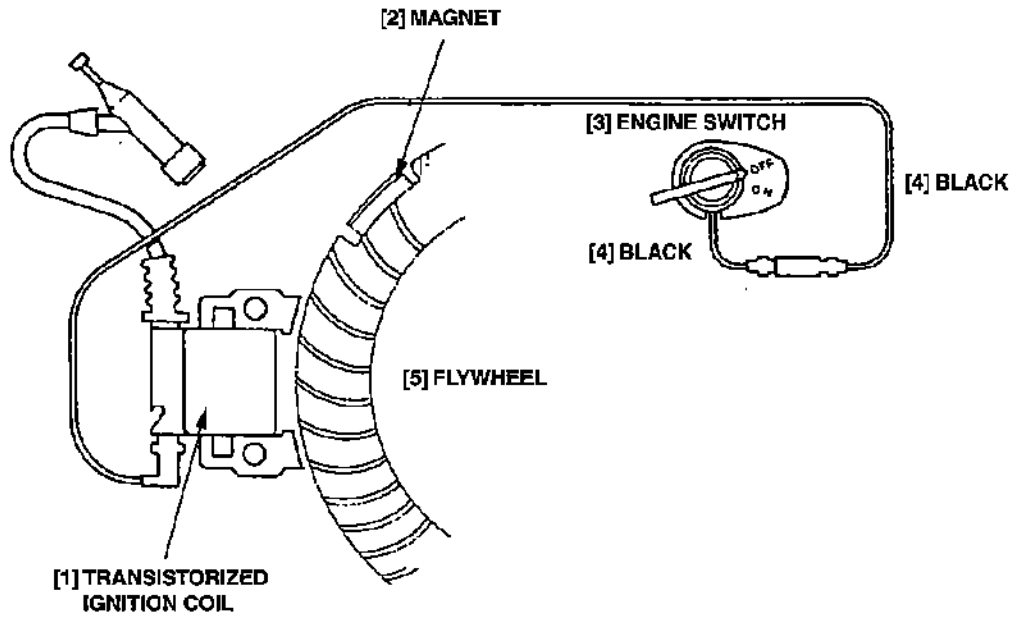

<Without electric starter/With oil alert>

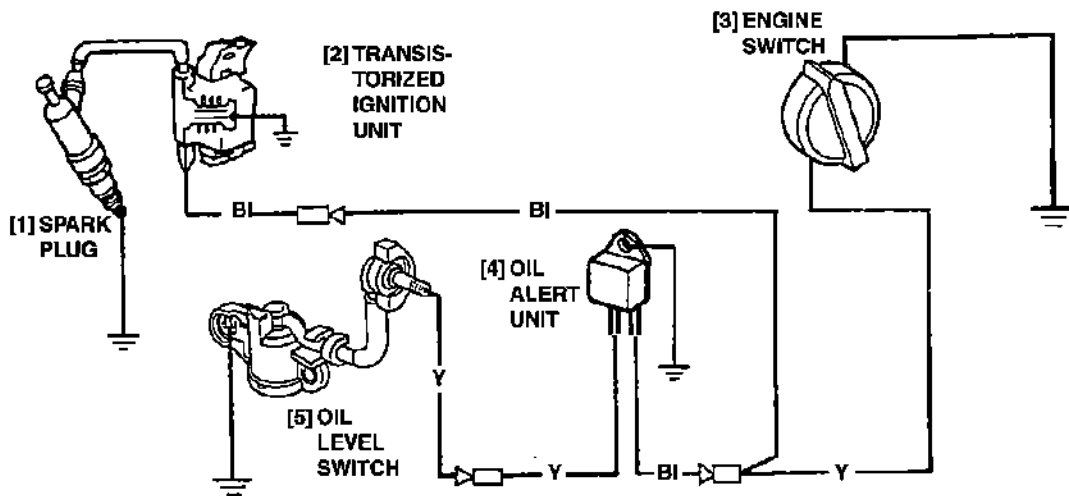

GENERAL SAFETY

Pay attention to these symbols and their meanings:

- ⚠ WARNING** Indicates a strong possibility of severe personal injury or death if instructions are not followed.
CAUTION: Indicates a possibility of personal injury or equipment damage if instructions are not followed.

⚠ WARNING

- Stop the engine, and remove the spark plug cap and ignition key before servicing.
- If the motor must be running to do some work, make sure the area is well ventilated. Never run the engine in a closed area; the exhaust contains poisonous carbon monoxide gas.
- Gasoline is extremely flammable and is explosive under certain conditions. Do not smoke or allow flames or sparks in your working area.

CAUTION

- Keep away from rotating or hot parts and high voltage wires when the engine is running.

SERVICE RULES

1. Use genuine Bonhoeffer or Bonhoeffer-recommended parts and lubricants or their equivalents. Parts that do not meet Bonhoeffer's design specifications may damage the engine.
2. Use the special tools designed for the engine.
3. Install new gaskets, O-rings, etc. when reassembling.
4. When torquing bolts or nuts, beginning with larger-diameter or inner bolts first and tighten to the specified torque diagonally, unless a particular sequence is specified.
5. Clean parts in cleaning solvent upon disassembly. Lubricate any sliding surfaces before reassembly.
6. After reassembly, check all parts for proper installation and operation.
7. Many screws used in this machine are self-tapping. Be aware that cross-threading or overtightening these screws will strip the female threads and ruin the hole.
8. Use only metric tools when servicing this engine. Metric bolts, nuts and screws are not interchangeable with nonmetric fasteners. The use of incorrect tools and fasteners will damage the engine.
9. Follow the instructions represented by these symbols when they are used:



: Apply oil



: Use special tool



: Apply grease

O x O (O) : Indicates the type, length, and number of the flange bolt used.

SERIAL NUMBER LOCATION

The engine serial number, the type and the variation are stamped on the crankcase. Refer to these when ordering parts or making technical inquiries

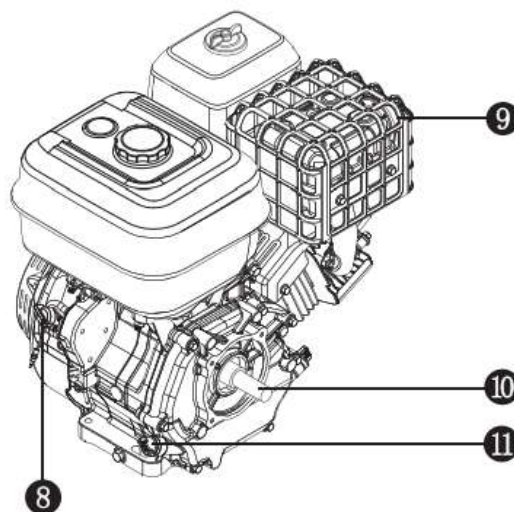

SPECIAL TOOLS

REF. NO	DESCRIPTION	APPLICATION
①	Float level gauge	Carburetor float level inspection
②	Attachment, 42 x 47 mm	6204 bearing installation
③	Attachment, 52 x 55 mm	6205, 62/22 bearing installation
④	Attachment, 62 x 68 mm	6206, 6305 bearing installation
⑤	Driver, 40 mm I.D.	Driver for tools 6, 7 and 8
⑥	Attachment, 25 mm I.D.	Timing gear installation (7HP to 16 HP)
⑦	Attachment, 30 mm I.D.	Governor drive gear timing gear (7HP to 16HP) installation
⑧	Attachment, 35 mm I.D.	Governor drive gear installation (7HP to 16HP)
⑨	Pilot, 22 mm	62/22 bearing installation
⑩	Pilot, 20 mm	6204 bearing installation
⑪	Pilot, 25 mm	6205, 6305 bearing installation
⑫	Pilot, 30 mm	6206 bearing installation
⑬	Driver	Driver for tools 2, 3 and 4
⑭	Valve seat cutter 45° ø24.5	Exhaust valve seat reconditioning (7HP to 16HP)
⑮	Valve seat cutter 45° ø27.5	Intake valve seat reconditioning (7HP to 16HP)
⑯	Valve seat cutter 45° ø22	Exhaust, intake valve seat reconditioning (7HP to 16HP)
⑰	Valve seat cutter 32° ø25	Exhaust valve seat reconditioning (7HP to 16HP)
⑱	Valve seat cutter 32° ø28	Intake valve seat reconditioning (7HP to 16HP)
⑲	Valve seat cutter 32° ø22	Exhaust, intake valve seat reconditioning (7HP to 16HP)
⑳	Valve seat cutter 60° ø30	Exhaust, intake valve seat reconditioning (7HP to 16HP)
㉑	Valve seat cutter 60° ø22	Exhaust, intake valve seat reconditioning (7HP to 16HP)
㉒	Valve seat cutter holder, 5.5 mm	Valve seat reconditioning
㉓	Valve guide driver	Valve guide removal/installation
㉔	Valve guide reamer	Valve guide I.D. reaming
㉕	Flywheel puller	Flywheel removal

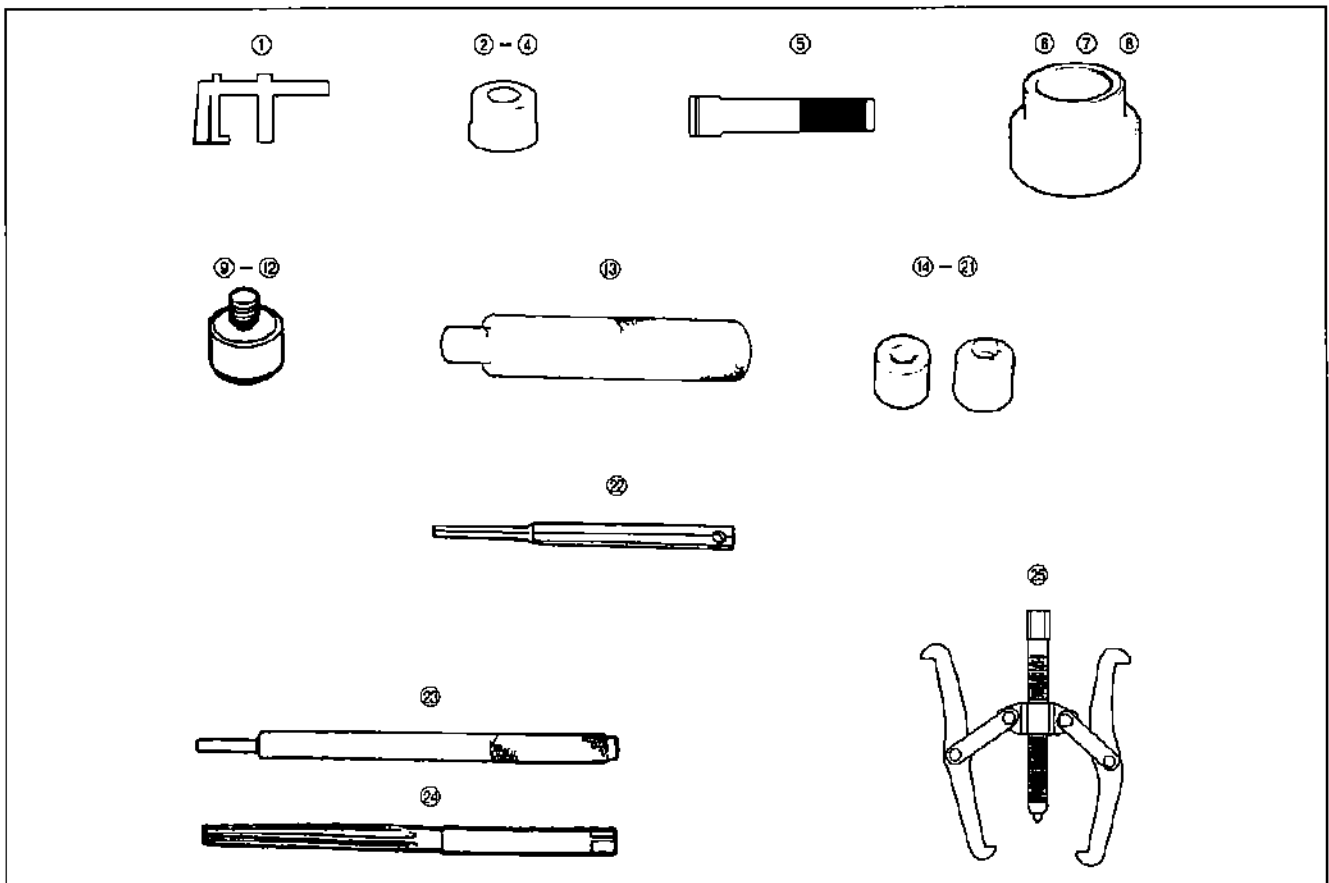

TROUBLESHOOTING

a. GENERAL SYMPTOM AND POSSIBLE CAUSES

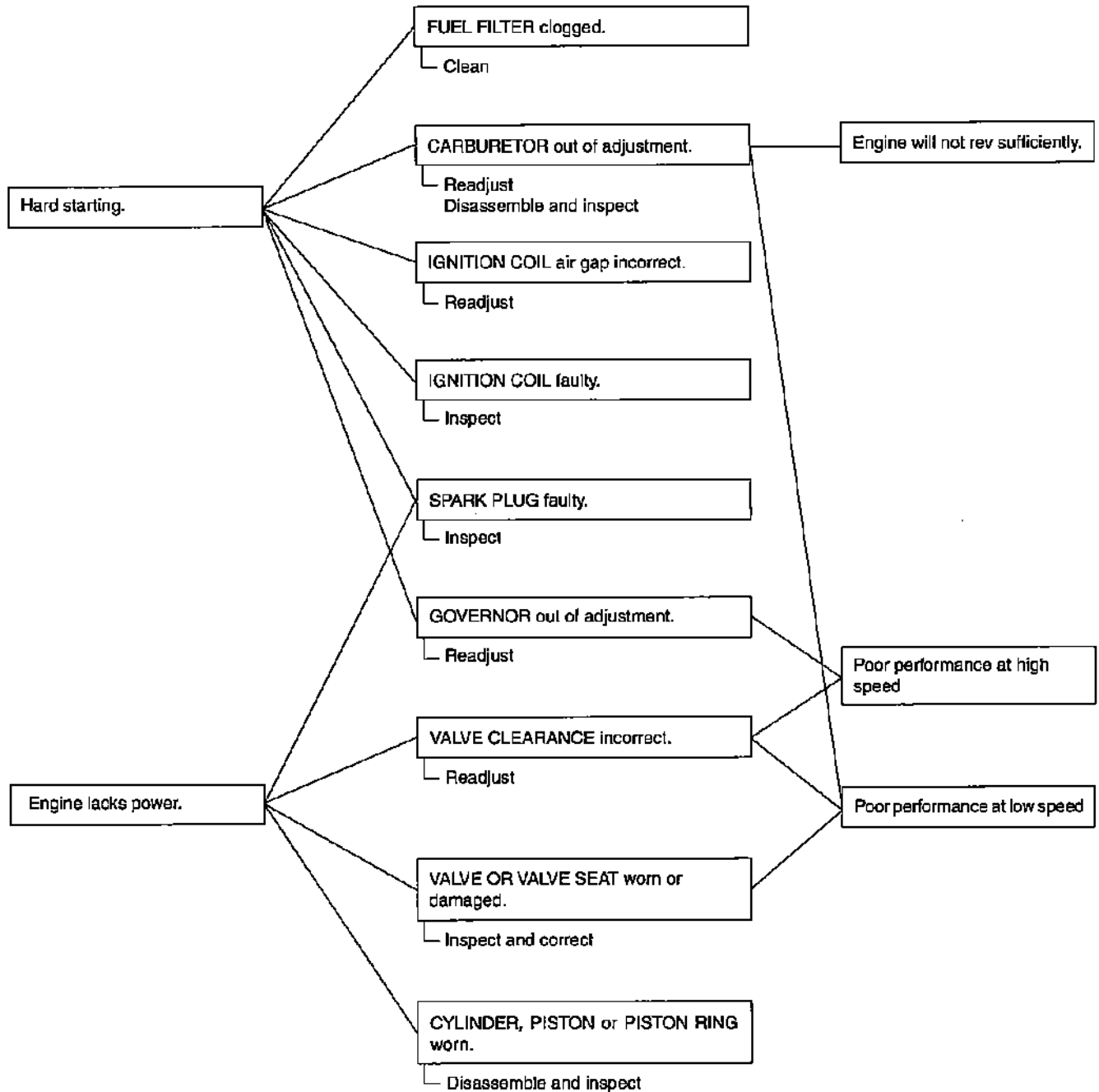

b. HARD STARTING

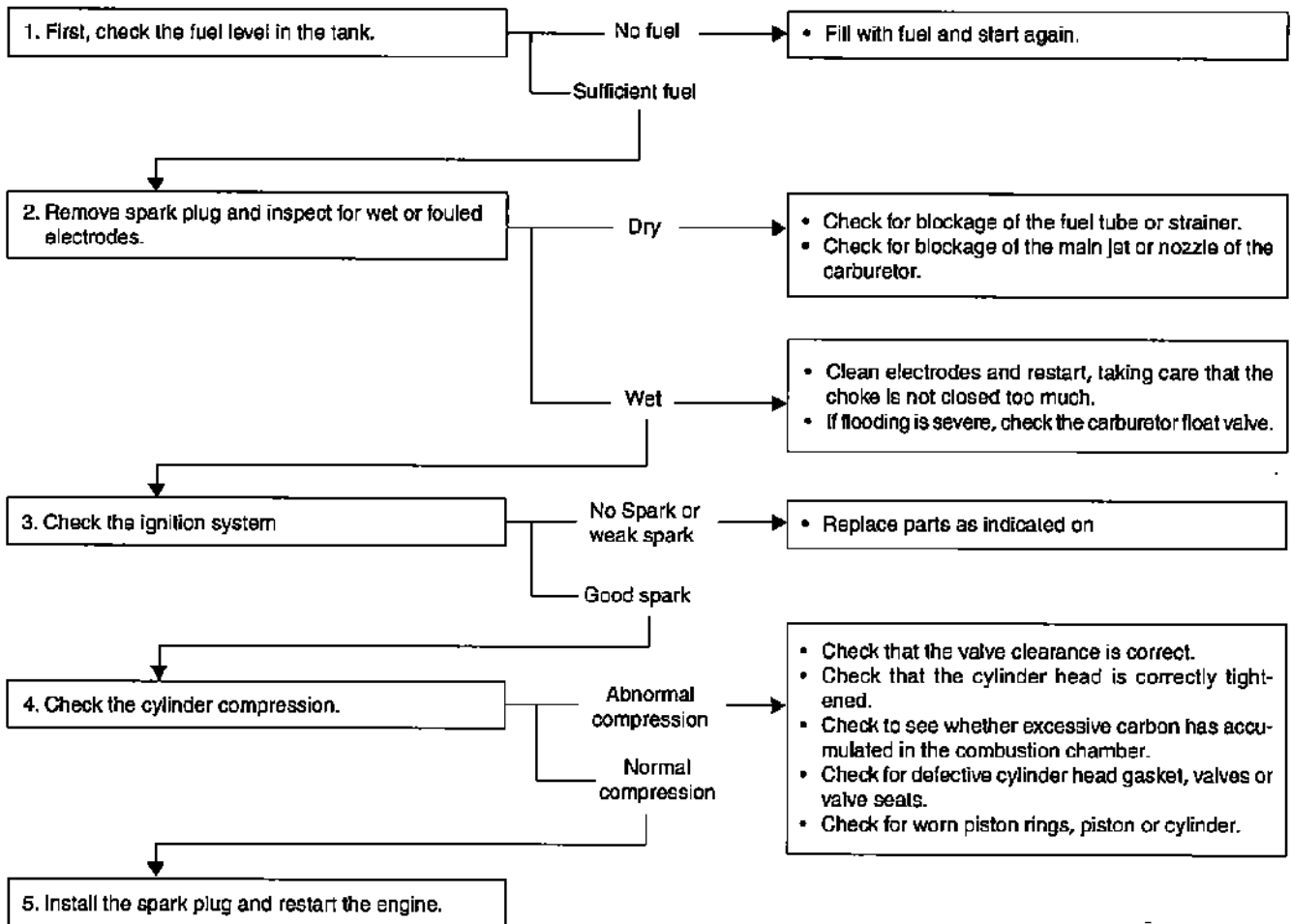

CYLINDER COMPRESSION CHECK

(Mechanical decompressor engaged)

- 1) Remove the spark plug and install a compression gauge in the spark plug hole.
- 2) Crank the engine several times with the recoil starter and measure the compression.

Compression	6.0 – 8.5 kg/cm ² (85 – 121 psi) at 600 min ⁻¹ (rpm)
-------------	--

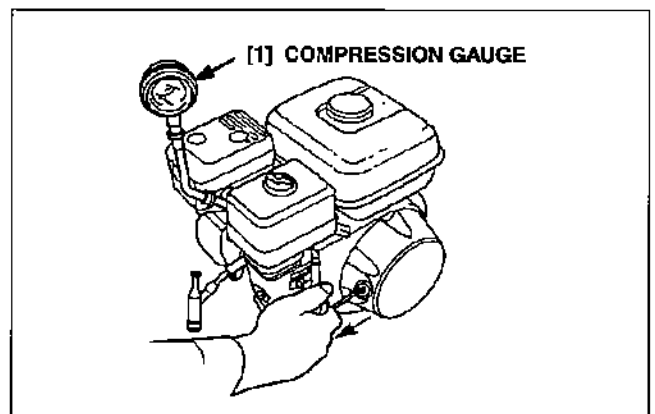

c. OIL ALERT SYSTEM

CAUTION

- Never start the engine when the oil has been drained.

- Engine Does not Start with Engine Switch ON.
- Check oil level before proceeding. Add the recommended engine oil if necessary.

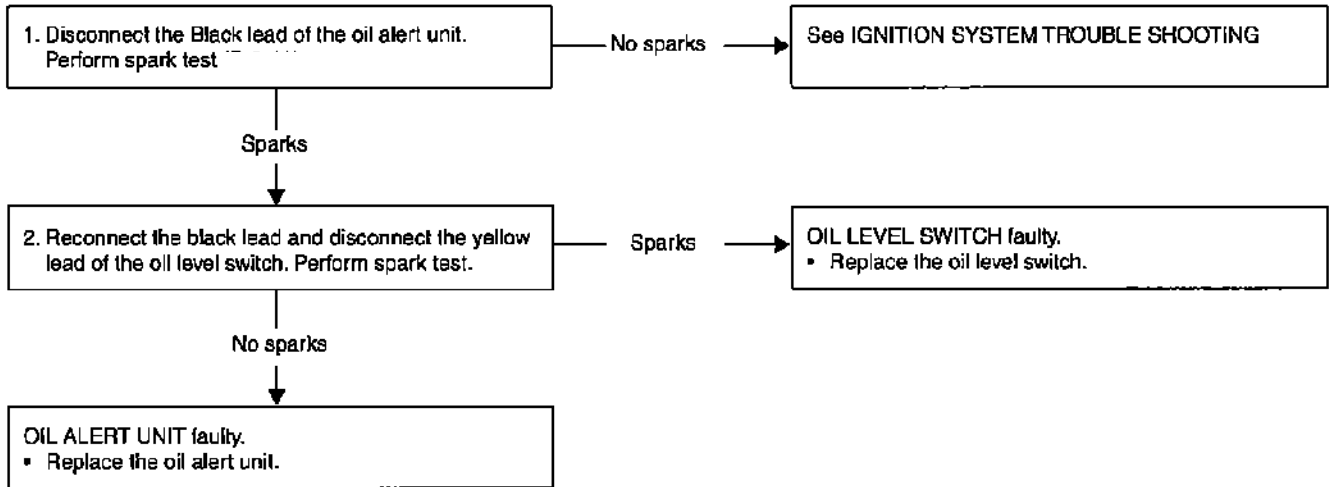

- Engine Does not Stop When the Engine oil Is Insufficient.
- Before proceeding, drain the engine oil.

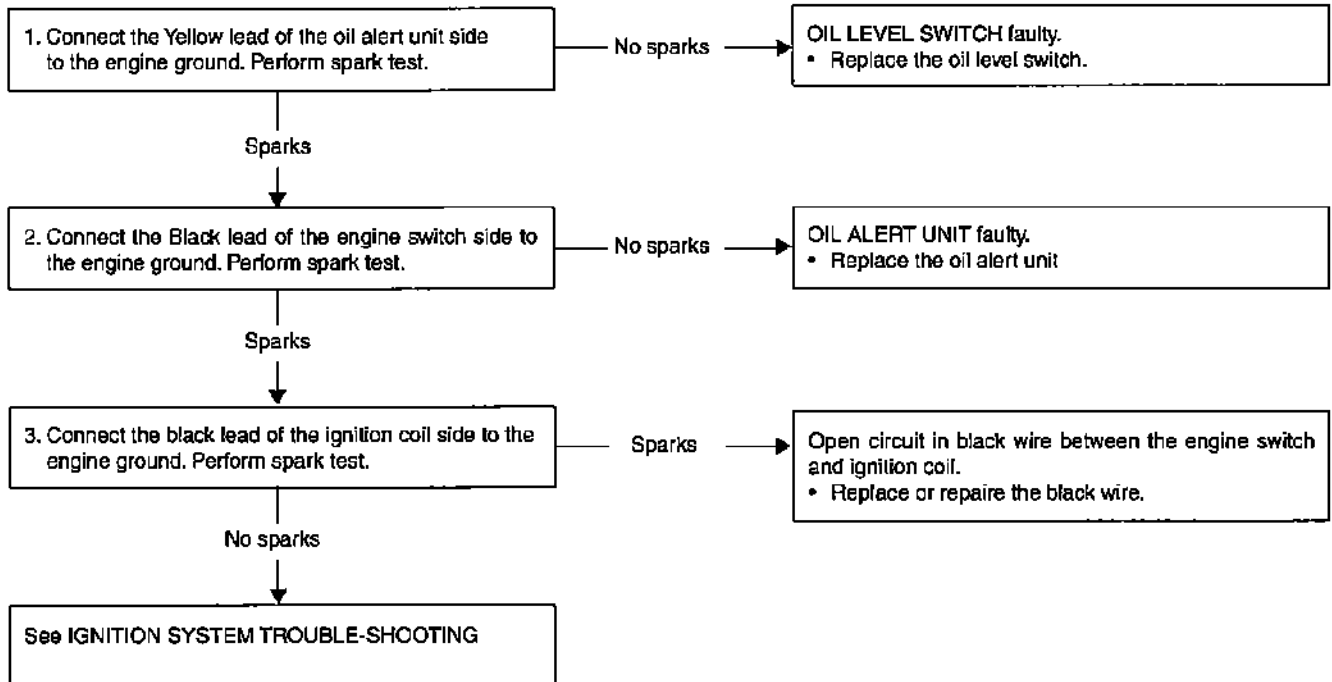

d. IGNITION SYSTEM

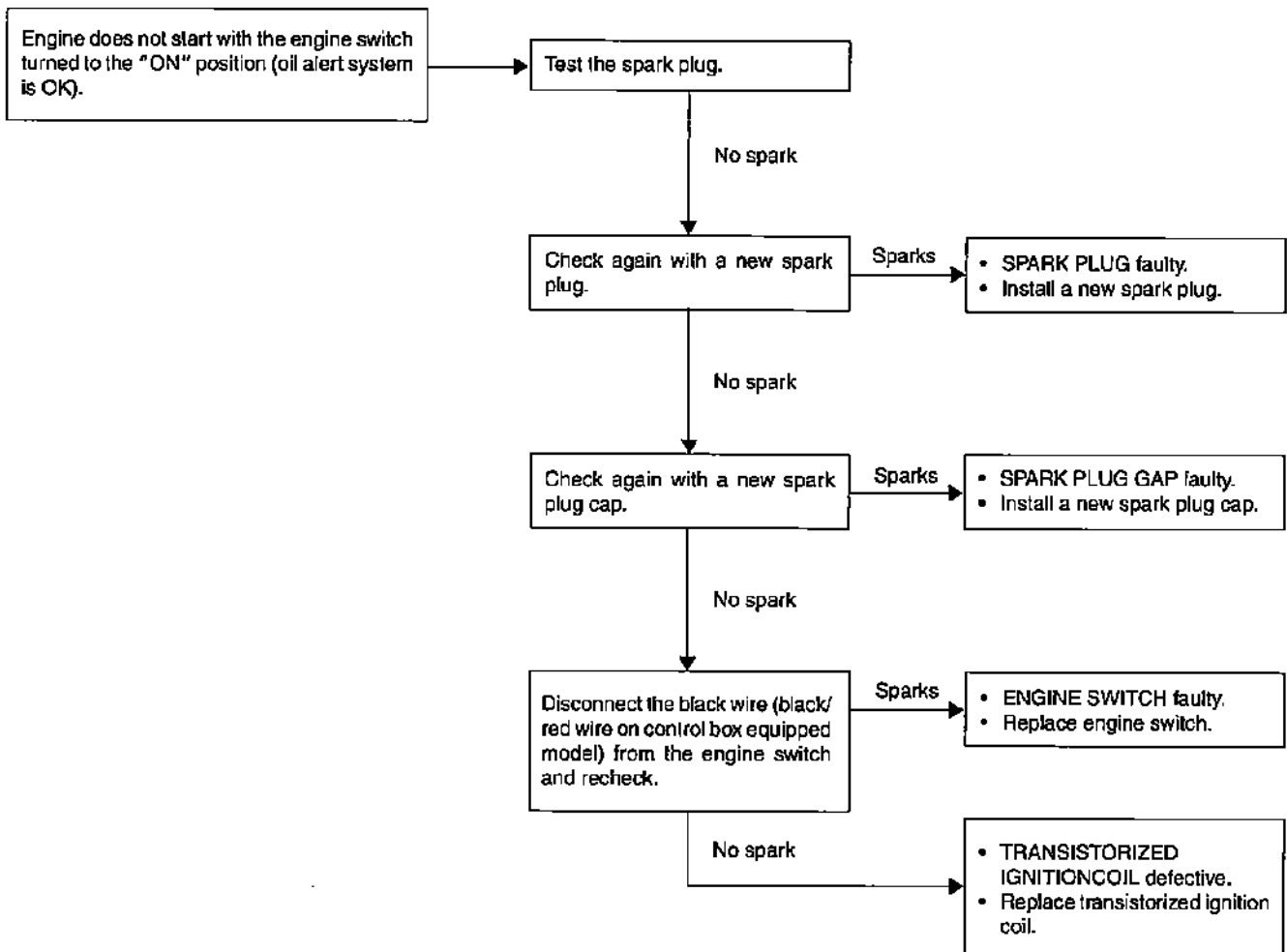

SPARK TEST

- 1) Remove the spark plug.
- 2) Install the spark plug to the spark plug cap and ground the side electrode against the cylinder head cover.
- 3) Turn the engine switch to the "ON" position, pull the recoil starter and check to see if sparks jump across the electrodes.

⚠ WARNING

- Never hold the spark plug lead with wet hands while performing this test.
- Make sure that no fuel has been spilled on the engine and the plug is not wet with fuel.
- To avoid fire hazards, do not allow sparks near the plug hole.

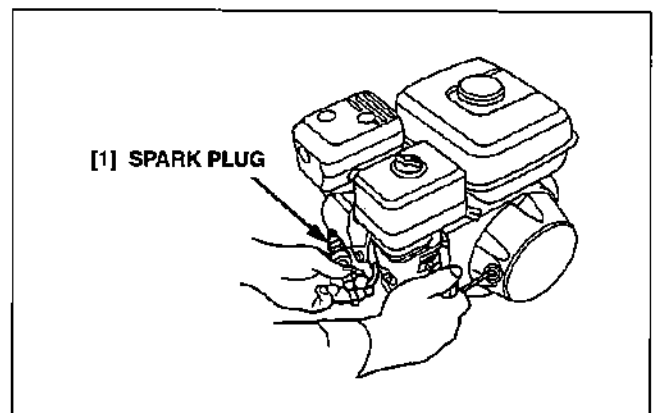



ENGINE OIL

NOTE

- Change the engine oil with the engine warm and in a horizontal position to assure complete and rapid draining.

- 1) Remove the oil filler cap/dipstick and drain bolt. Allow the oil to drain completely.
- 2) Reinstall the drain bolt, and tighten it of specified torque.
- 3) Fill the crankcase with the recommended engine oil to the outer edge of the oil filler neck. Reinstall the filler cap/dipstick.

SAE 10W-30 is recommended for general, all temperature use.
Other viscosities shown in the chart may be used when the average temperature in your area is within the indicated range

CAUTION

- Do not overfill with engine oil.
- Check engine oil with the engine positioned horizontally.
- Used engine oil may cause skin cancer if repeatedly left in contact with the skin for prolonged periods. Although this is unlikely unless you handle used oil on a daily basis, it is still advisable to thoroughly wash your hands with soap and water as soon as possible after handling used oil.

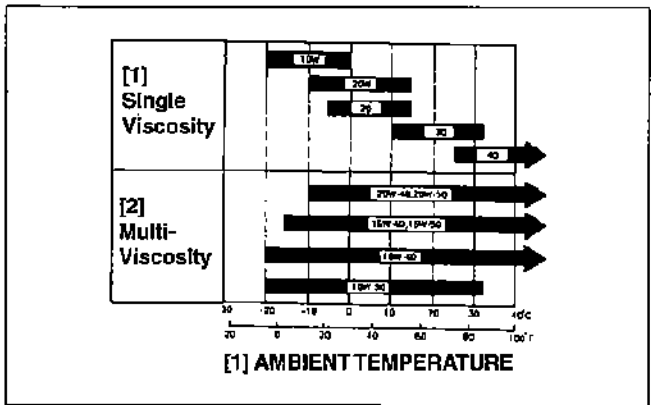
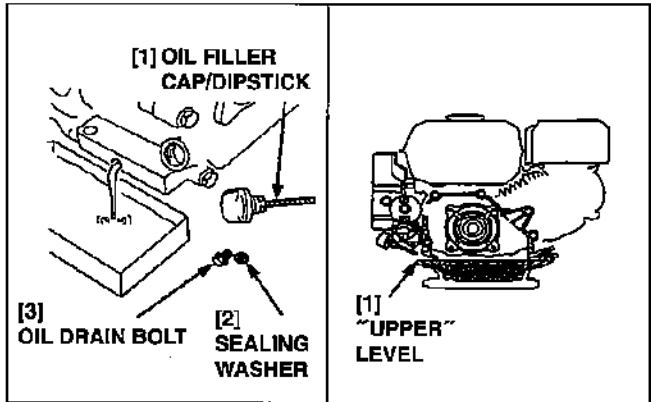

REDUCTION CASE OIL

1/2 Reduction (Centrifugal clutch type):

- 1) Remove the oil filler cap/dipstick, and drain bolt. Allow the oil to drain completely.
- 2) Reinstall the drain bolt, and tighten it to specified torque.
- 3) Fill the reduction case with the same oil that is recommended for the engine. Fill to the upper limit mark on the dipstick.

CAUTION

- Check the engine oil with the engine positioned horizontally.

1/6 Reduction:

- 1) Remove the filler bolt and oil level bolt. Tilt the engine to drain the used oil through the oil level bolt hole. Allow the oil to drain completely.
- 2) Stand the engine upright, and fill the reduction case with the same oil that is recommended for the engine. Fill until oil starts to flow from the oil level bolt hole.
- 3) Install the oil level bolt and filler bolt. Tighten them to the specified torque.

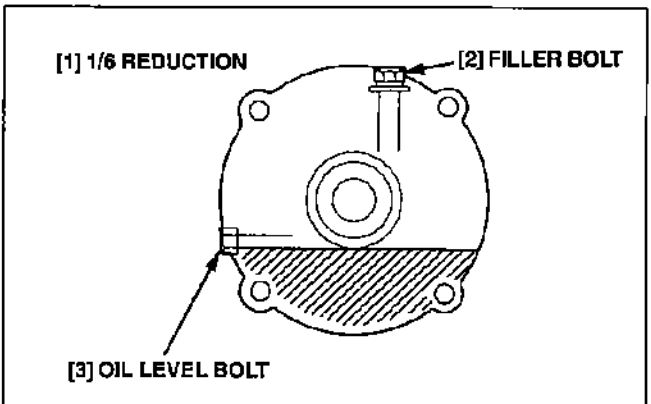
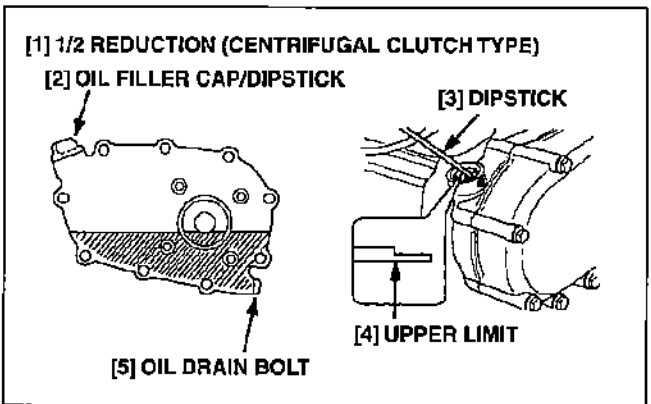

OIL ALERT

NOTE

For convenience, perform this test in conjunction with the engine oil change.

- 1) With the engine running, disconnect the yellow lead from the oil level switch, and ground the lead to the engine. The engine should stop.
- 2) With the engine stopped and the engine oil drained, check for continuity between the oil level switch lead and engine ground. There should be continuity.
- 3) With the crankcase filled with oil, check for continuity between the yellow oil level switch lead and engine ground. There should be no continuity.

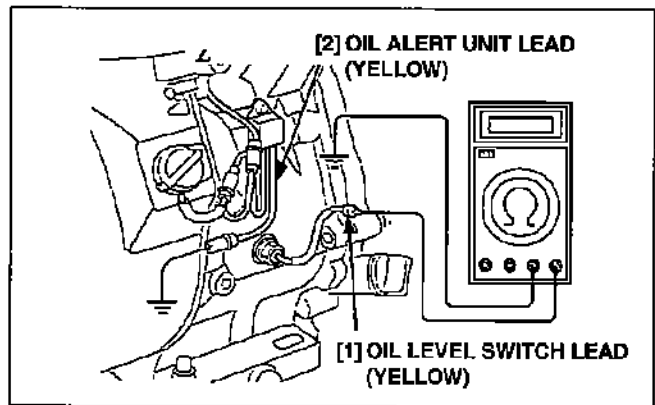

AIR CLEANER

⚠ WARNING

• Never use gasoline or low flash point solvents for cleaning the air cleaner element. A fire or explosion could result.

Dual element, cyclone type:

- 1) Remove the nut, air cleaner cover and wing nut. Remove the air cleaner elements and separate them. Carefully check both elements for holes or tears and replace if damaged.
- 2) Paper element: Tap the element lightly several times on a hard surface to remove excess dirt or blow compressed air lightly (30 PSI or less) through the filter from the inside out. Never try to brush the dirt off; brushing will force dirt into the fibers.

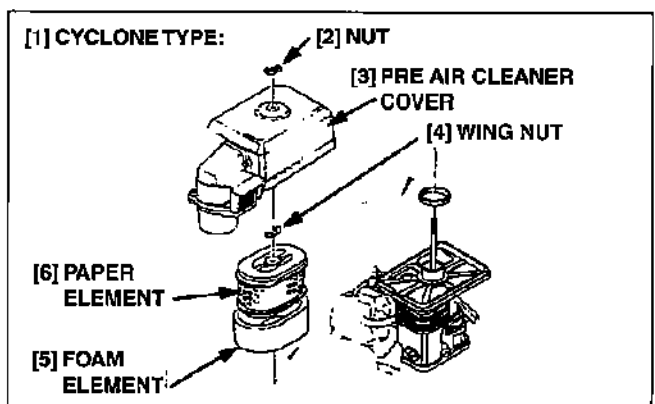
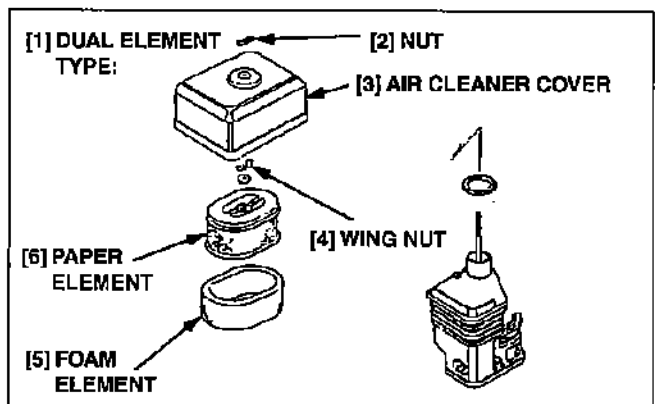

- 3) Foam element: Clean in warm soapy water, rinse and allow to dry thoroughly. Dip the element in clean engine oil and squeeze out all the excess. The engine will smoke during initial start-up if too much oil is left in the foam.
- 4) Shine a light through the elements, and inspect them carefully. Reinstall the elements if they are free of holes and tears. If the air filter still affects engine performance, replace it with a new one.

CAUTION

- Carefully check both elements for holes or tears and replace as required. Damaged elements will allow dirt to pass into the engine, causing rapid wear. Always clean the filter housing and air passages before installing clean elements.

NOTE

- The engine will run poorly when the air cleaner needs maintenance. If it runs better without the air cleaner than it does with the elements, or if the length of time between cleanings keeps getting shorter, replace the elements. Under extremely dusty conditions such as volcanic ash, etc., the system may need daily maintenance.

Semi-dry type:

- 1) Remove the wing nut, air cleaner cover and foam element. Carefully check the element for holes or tears and replace if damaged.
- 2) Clean, wash and oil the foam element.

Oil bath type:

- 1) Remove the wing nut, air cleaner cover and foam element. Carefully check the element for holes or tears and replace if damaged.
- 2) Clean, wash and oil the foam element.
- 3) Empty the oil from the air cleaner case, and wash out any accumulated dirt with solvent. Dry the case.

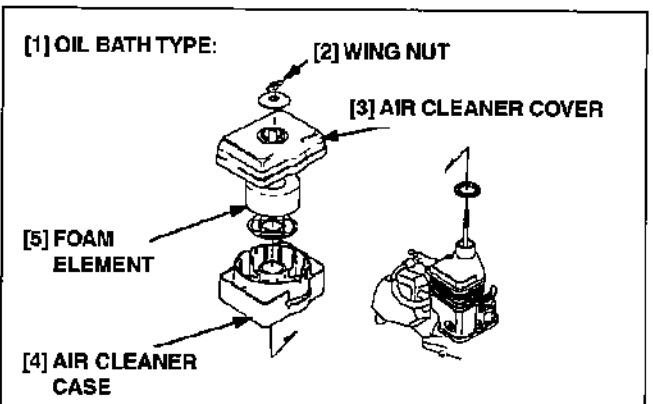
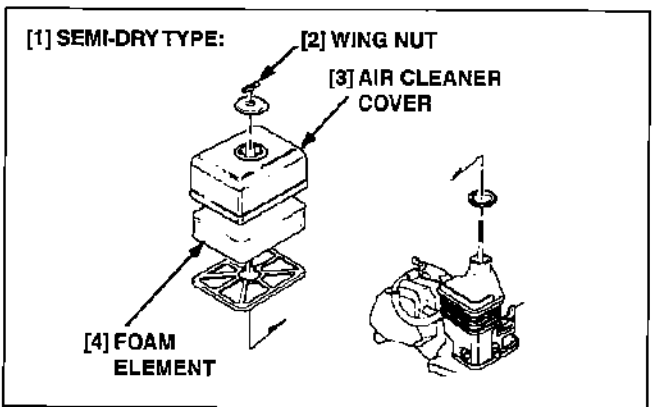
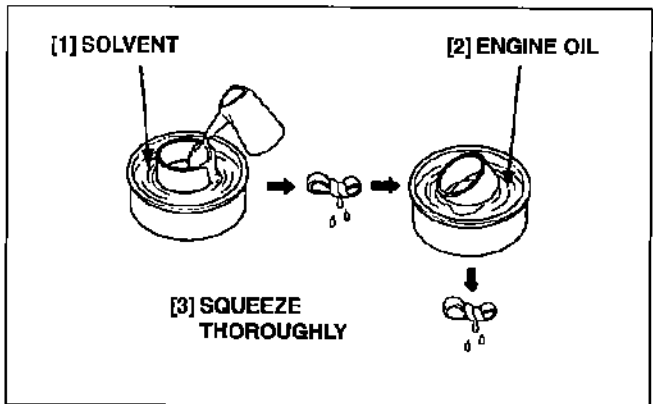

- 4) Fill the air cleaner case to the level mark with the same oil that is recommended for the engine see engine oil recommendation on

NOTE

- Do not overfill the air cleaner case. An excessive oil level will saturate the foam element and restrict air flow.

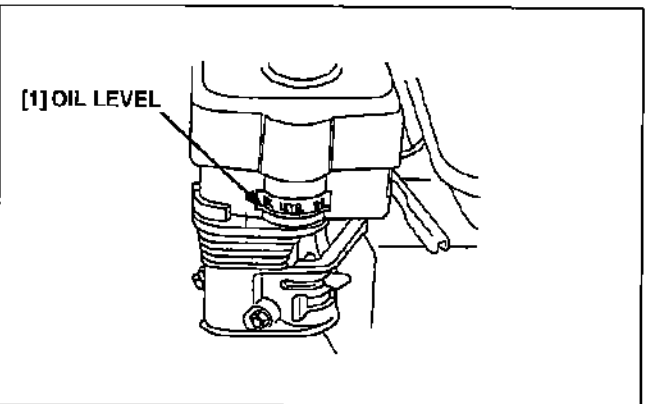

VALVE CLEARANCE

NOTE

- Valve clearance inspection and adjustment must be performed with the engine cold.

1) Remove the four cylinder head cover bolts, cylinder head cover and gasket.

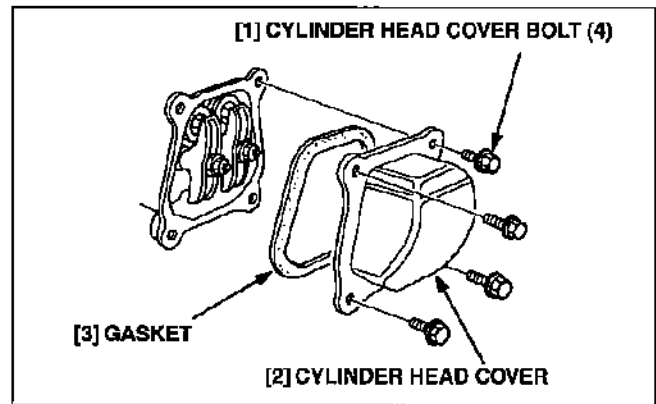

2) Set the piston at top dead center of the compression stroke (both valves fully closed). The triangular mark on the starter pulley will align with the top hole on the fan cover when the piston is at top dead center of the compression or exhaust stroke.

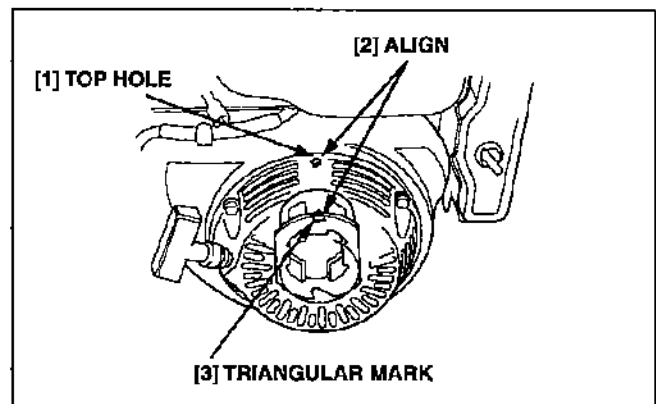

3) Insert a feeler gauge between the rocker arm and valve to measure valve clearance.

Standard valve clearance	IN	0.15 ± 0.02 mm (0.006 ± 0.001 in)
	EX	0.20 ± 0.02 mm (0.008 ± 0.001 in)

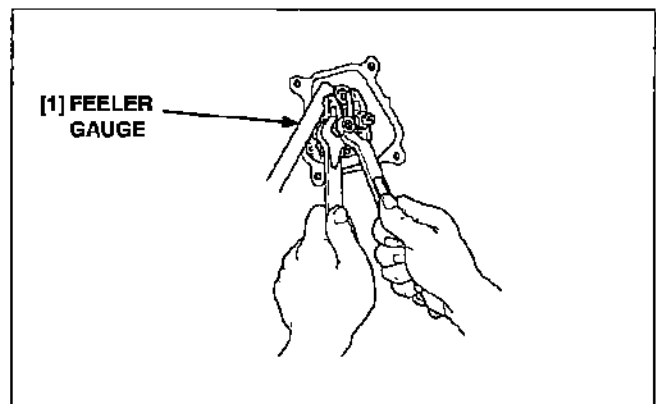

4) If adjustment is necessary, proceed as follows:

- Hold the rocker arm pivot and loosen the rocker arm pivot lock nut.
- Turn the rocker arm pivot to obtain the specified clearance.
- Retighten the rocker arm pivot lock nut while holding the rocker arm pivot.
- Recheck valve clearance after lightening the rocker arm pivot lock nut.

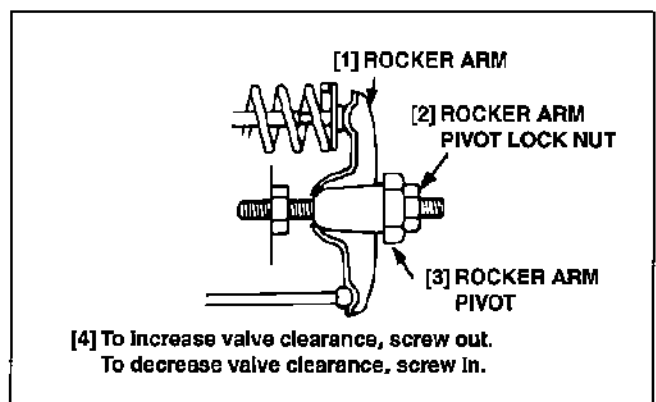

SPARK PLUG

- 1) Visually inspect the spark plug. Discard the plug if the insulator is cracked or chipped.
- 2) Remove carbon or other deposits with a stiff wire brush.
- 3) Measure the plug gap with a wire-type feeler gauge.

Spark plug gap	0.7 – 0.8 mm (0.028 – 0.031 in)
----------------	---------------------------------

If necessary, adjust the gap by bending the side electrode.

- 4) Make sure the sealing washer is in good condition; replace the plug if necessary.
- 5) Install the plug fingertight to seat the washer, then tighten with a plug wrench (an additional 1/2 turn if a new plug) to compress the sealing washer. If you are reusing a plug, tighten 1/8 – 1/4 turn after the plug seats.

CAUTION

- The spark plug must be securely tightened. An improperly tightened plug can become very hot and possibly damage the engine.
- Never use a spark plug with an improper heat range.

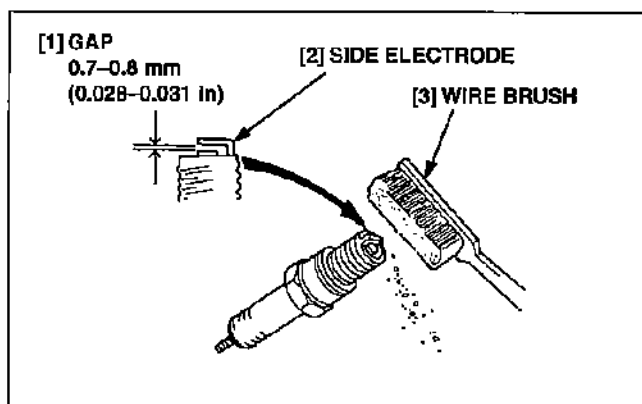

CARBURETOR

- 1) Start the engine and allow it to warm up to normal operating temperature.
- 2) With the engine idling, turn the pilot screw in or out to the setting that produces the highest idle min^{-1} (rpm). The correct setting will usually be obtained at approximately the following number of turns out from the fully closed (lightly seated) position.

		EXTERNAL	INTERNAL
Pilot screw opening	(7HP to 16HP)	2 turns out	2-3/8 turns out
	(7HP to 16HP)	3 turns out	2-1/8 turns out

- 3) After the pilot screw is correctly adjusted, turn the throttle stop screw to obtain the standard idle speed.

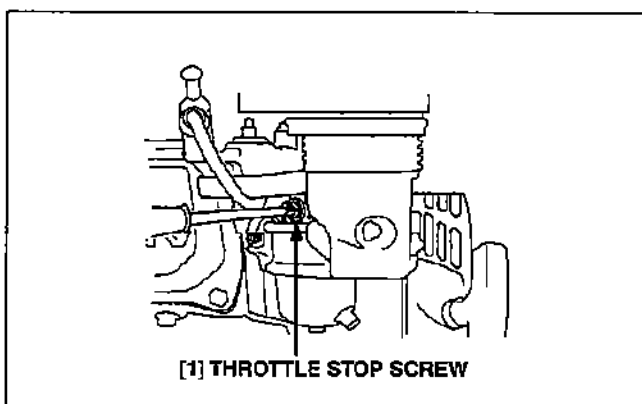
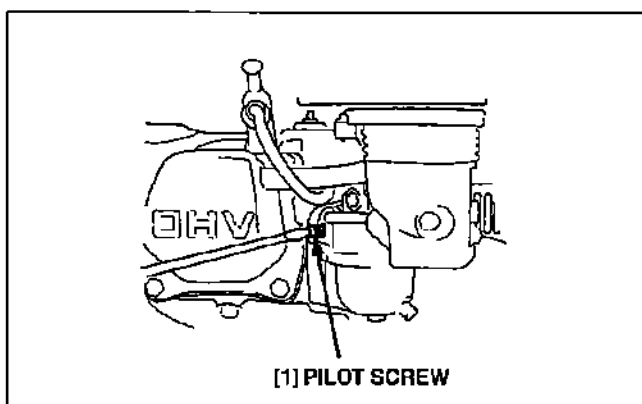

GOVERNOR

- 1) Remove the fuel tank
- 2) Loosen the nut on the governor arm and move the governor arm to fully open the throttle.
- 3) Rotate the governor arm shaft as far as it will go in the same direction the governor arm moved to open the throttle. Tighten the nut on the governor arm.
- 4) Start the engine and allow it to warm up to normal operating temperature. Move the throttle lever to run the engine at the standard maximum speed, and adjust the throttle lever limiting screw so the throttle lever cannot be moved past that point.

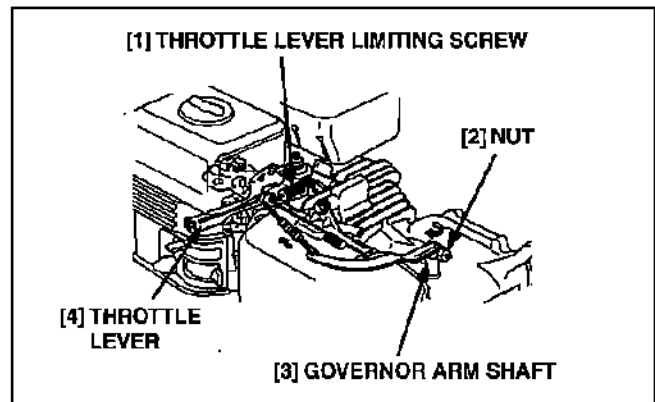

FUEL STRAINER

⚠ WARNING

- Gasoline is extremely flammable and is explosive under certain conditions. Do not smoke or allow flames or sparks in the area.
- After installing the fuel filter, check for leaks, and make sure the area is dry before starting the engine.

- 1) Turn off the fuel valve and remove the strainer cup.
- 2) Clean the strainer cup with solvent.
- 3) Install the O-ring and strainer cup. Tighten the strainer cup to the specified torque.

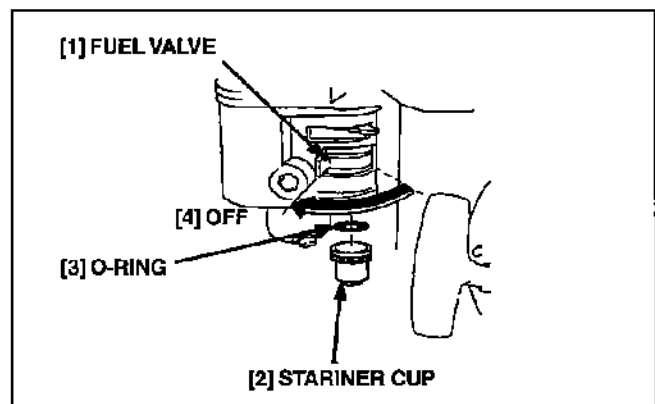

SPARK ARRESTER (Optional parts)

⚠ WARNING

- The muffler becomes very hot during operation and remains hot for a while after stopping the engine. Be careful not to touch the muffler while it is hot. Allow it to cool before proceeding.

CAUTION

- The spark arrester must be serviced every 100 hours to maintain its efficiency.

- 1) Remove the four 5 x 8 mm tapping screws from the upper muffler protector.
- 2) Remove the upper muffler protector.
- 3) Remove the 4 x 8 mm screw and spark arrester. Be careful not to damage the wire mesh of the spark arrester.
- 4) Check the carbon deposits around the exhaust port and spark arrester. Clean, if necessary. Replace the spark arrester if there are any breaks or tears.
- 5) Install the spark arrester and muffler in the reverse order of removal.

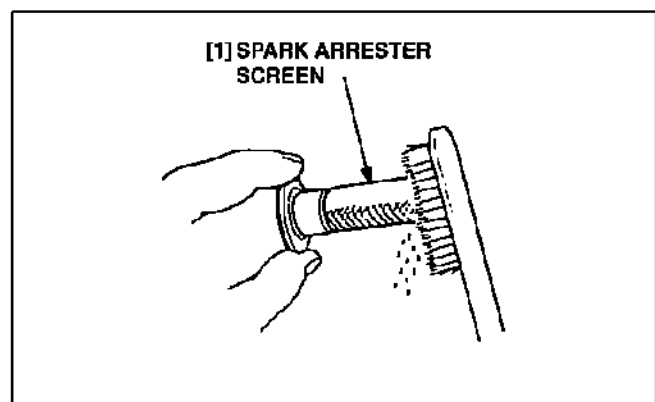
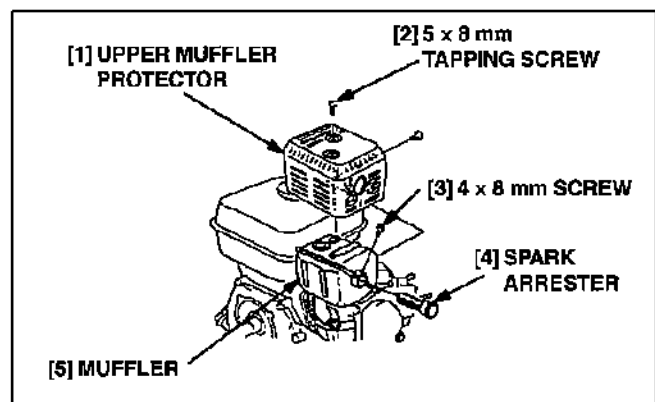

FUEL FILTER

⚠ WARNING

- Gasoline is extremely flammable and is explosive under certain conditions. Do not smoke or allow flames or sparks in the area.
- After installing the fuel filter, check for leaks, and make sure the area is dry before starting the engine.

- 1) Drain the fuel into a suitable container, and remove the fuel tank
- 2) Disconnect the line, and unscrew the fuel filter from the tank.
- 3) Clean the filter with solvent, and check to be sure the filter screen is undamaged.
- 4) Place the O-ring on the filter and reinstall. Tighten the filter to the specified torque. After reassembly, check for fuelleakes.

TORQUE: 2 N·m (0.2 kg-m.)

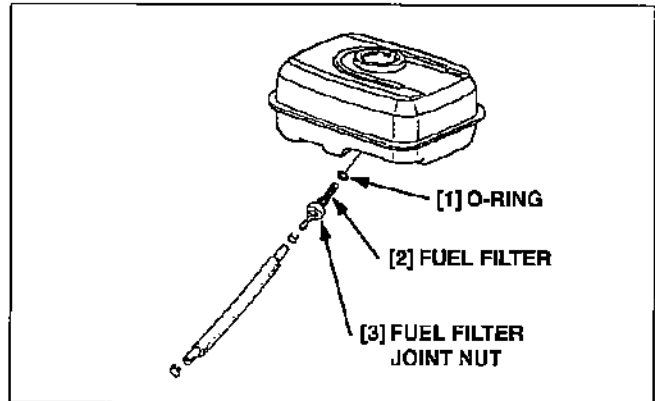

BON-P-GE-7.0HP

1. Mounting dimensions

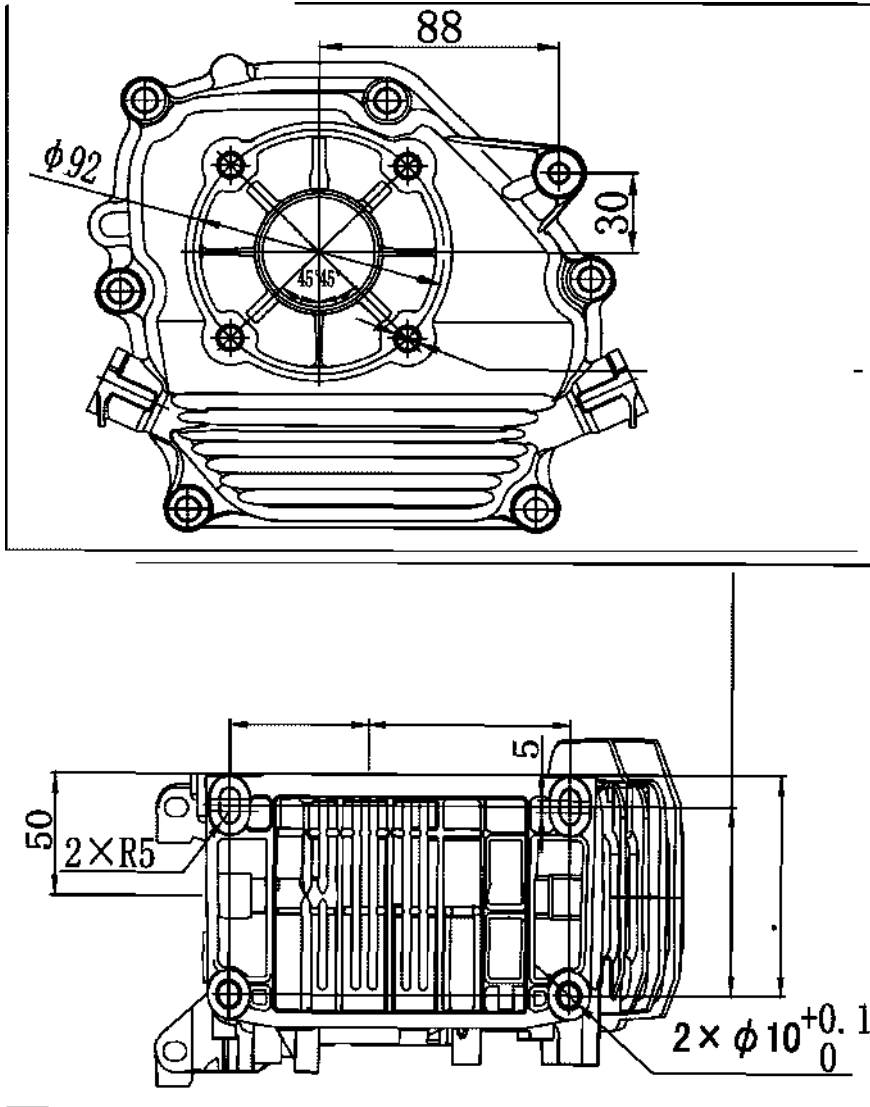

Crankshaft output (which can be adjusted according to the requirements of the customer)

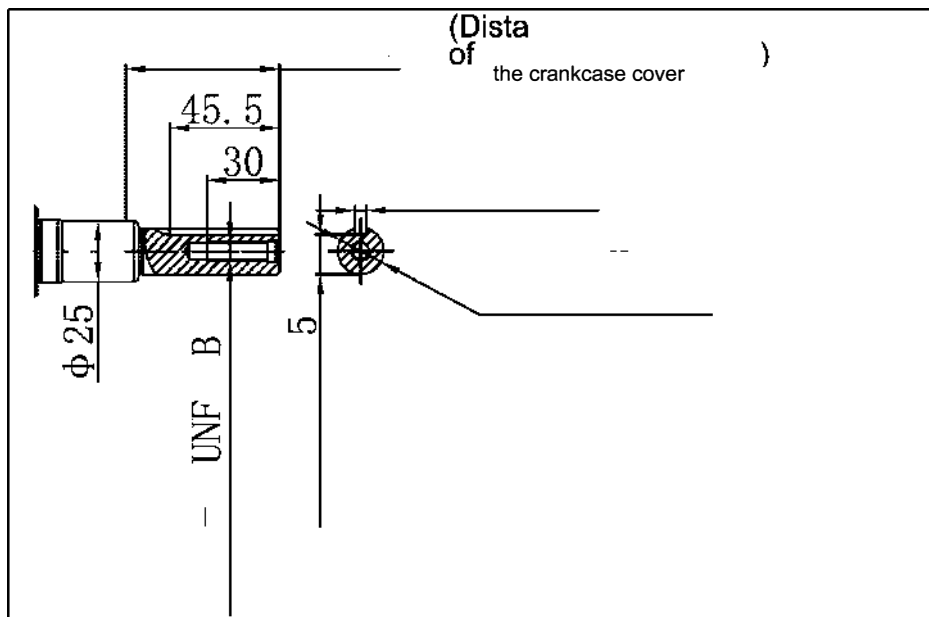

BON-P-GE-9.0HP

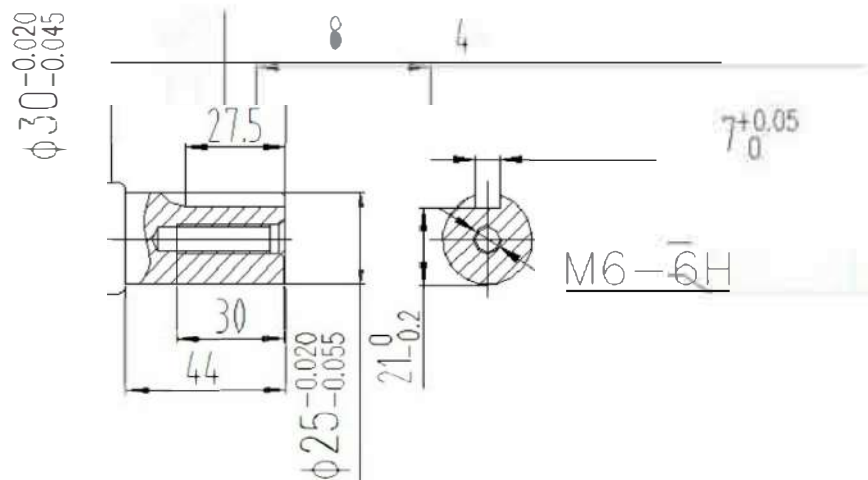
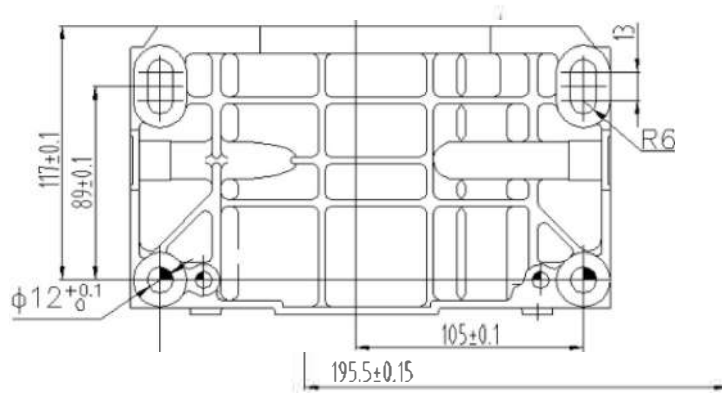
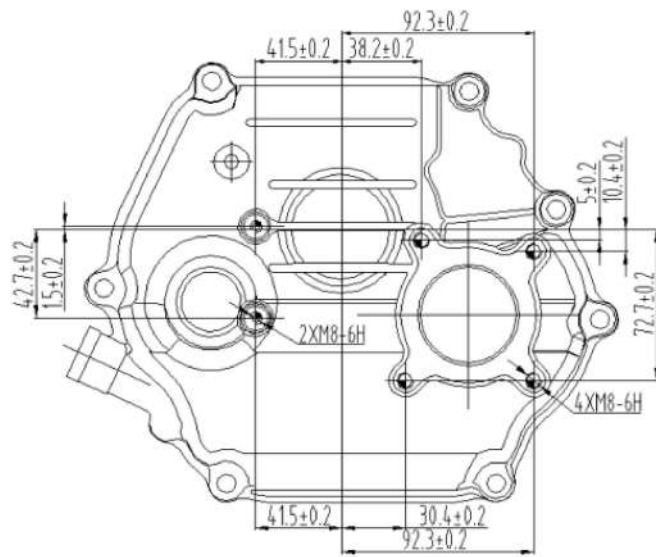

BON-P-GE-13.0HP

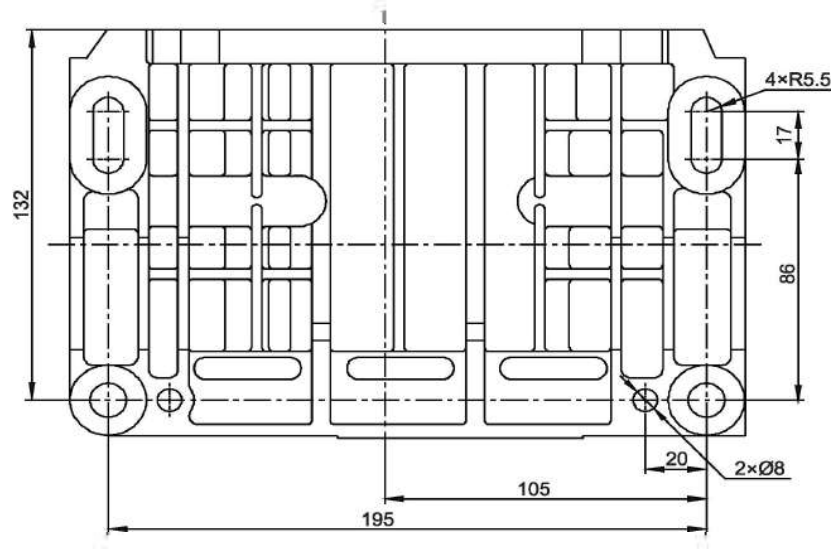
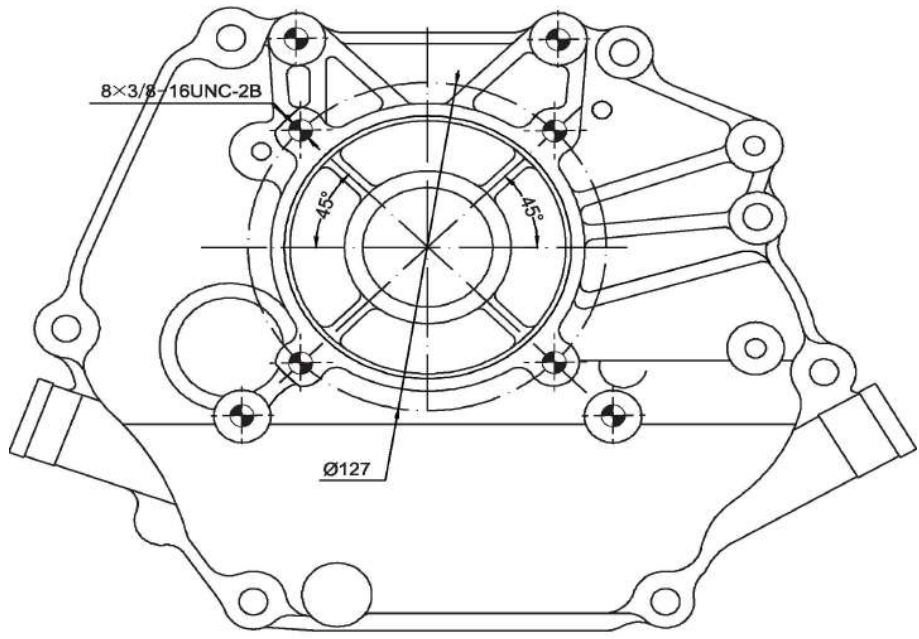

BON-P-GE-14.0HP

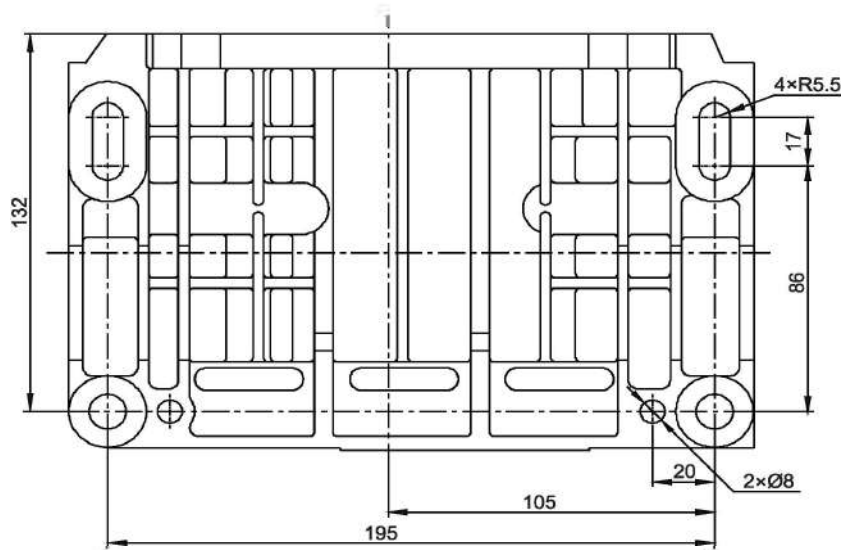
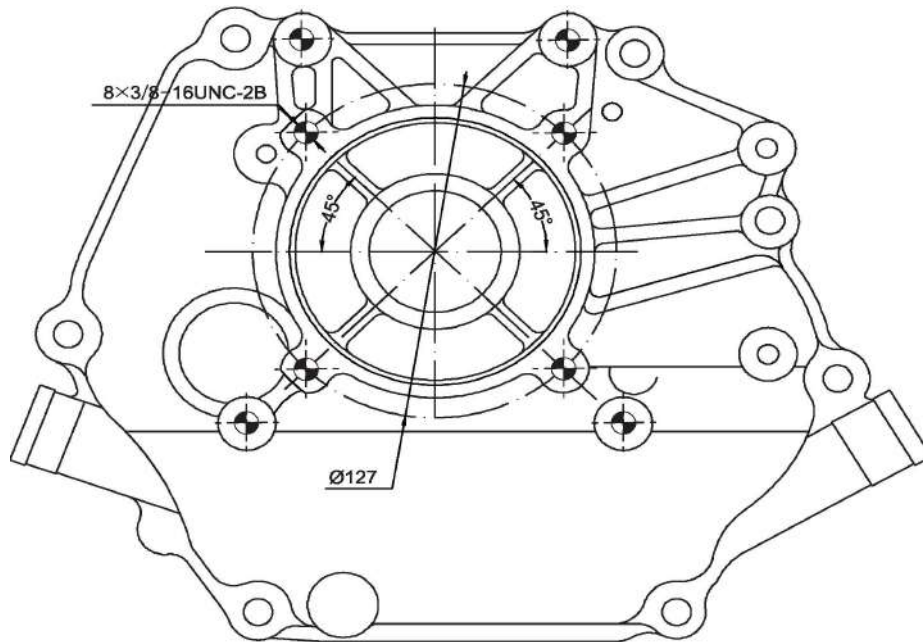



BONHOEFFER



SCAN
TO
VISIT
WEBSITE



Bonhoeffer Machines



Bonhoeffer_Machines



Bonhoeffer Machines

CORPORATE OFFICE:

PLOT NO. 756, UDYOG VIHAR PHASE-5, GURUGRAM,
HAR ANA - 122016, INDIA

sales@bonhoeffermachines.com